

ROTARY TUMBLER

INSTRUCTIONS AND PARTS LIST

**Model
C300**

**Model
C100**



**Model
C200**

LORTONE

12130 Cyrus Way
Mukilteo, WA 98275
(425) 493-1600

GETTING STARTED

- I. **Open the Barrel:** Remove nut and washer, press down on bolt with thumb while lifting up on outside of outer lid with fingers. If outer lid is difficult to remove, insert washer between edge of outer lid and barrel, twist to loosen. After outer lid has been removed, lift inner lid out by center bolt.



- II. **Add Rocks:** Fill Barrel about 1/2 to 2/3 full of rock. Rocks should be of assorted sizes for best results.
- III. **Add Abrasive:** Add 60/90 Silicon Carbide Abrasive. Use 1-1/4 C. for a 12 lb. barrel. Add water to top layer of rocks and abrasive.

Do not overfill.

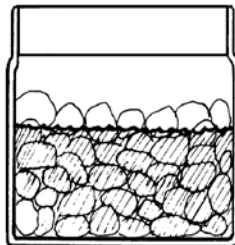

Add rocks until 2/3 full. Add water to top layer of rocks.

IV. Close the Barrel: Wipe the mating surfaces of the barrel and inner lid clean with a damp cloth. Press inner lid into barrel until it rests on shoulder. Press outer lid firmly down onto the barrel. Install washer and tighten nut.

Knurled nut only needs to be snug Do Not Use tools to tighten. Over tightening of the nut can cause the inner lid to distort and leak.

V. Tumble: Plug the tumbler into a suitable outlet. Place the barrel on the tumbler making sure the groove in the barrel nut sits on the tumbler guide. Tumble for 2-3 days. Open and check the rocks. The rough edges should be wearing down. After 5-7 days, open the barrel and rinse the rocks in a bucket of water. DO NOT put the rinse water down a household drain as it will clog the drain!

IMPORTANT: Clean the rocks and barrel parts thoroughly using mild soap and water!

VI. Repeat steps II through V: Use succesively finer abrasives according to your tumbling instruction booklet and the chart below:

	Step 1	Step 2	Step 3	Step 4
Compound	60/90 Silicon Carbide	120/220 Silicon Carbide	Pre-Polish Aluminum Oxide	Polish Aluminum Oxide
12 lb Barrel	1-1/4 C.	1-1/4 C.	1-1/2 C.	1-1/2 C.

TROUBLESHOOTING

If your tumbler fails to operate correctly, check the following:

Barrel does not turn, turns very slowly, or stops after being placed on tumbler.

No power to unit.	Make sure machine is plugged in correctly. Make sure electrical circuit is operational.
Barrel not installed correctly.	Align barrel correctly.
Barrel too heavy.	Do not exceed rated capacity.
Drive belt broken.	Remove cover and replace belt.
Motor doesn't run or runs intermittently.	Replace motor.

Barrel leaks or barrel lid comes off during operation.

Inner lid not seated correctly.	Make sure inner lid and barrel shoulder are clean and free of contaminants. Make sure inner lid is seated on shoulder inside barrel.
Knurled nut over tightened.	Tighten knurled nut by hand only until snug. Do not use tools.
Gas build-up in barrel.	Open barrel occasionally to vent gas that might be formed during tumbling.
Barrel or boot gasket damaged.	Replace damaged barrel or boot gasket.

MAINTENANCE

LORTONE Tumblers are capable of operating 24 hours/day for years with proper care.

For best operation and results follow these simple, but important steps:

MOTOR: The motor is designed for continuous use and does not need oiling or other maintenance. It is normal for the motor to run hot to the touch.

CLEANING: The outside of the barrel should be kept clean. Clean by wiping with a wet soapy cloth and rinse well with fresh water. **DO NOT** put the barrel in a dishwasher or clean using solvents. If the outside of the barrel becomes so slick that it slips on the rollers, roughen slightly with very fine sandpaper or steel wool.

If you need assistance, please contact:
Lortone Customer Service (425) 493-1600 or
email: equipment@Lortone.com

PARTS LIST C100

Part No.	Description
A 200-002	Bearing
B 203-920	Bearing, Nylon
C 204-002	Bearing Strap
D 210-023	Belt, Drive
E 210-025	Belt, Idler
F 211-001	Pulley, 1-1/2" x 1/2"
G 211-006	Pulley, 2" x 5/8"
H 211-041	Pulley, 5" x 5/8"
I 300-030	1/6 HP Motor
J 009-005	Shaft with cover
K 481-029	Nut, Hex, 5/16"-18 x 1-1/2"
L 484-015	Bolt, Hex, 1/4"-20, 3/4"
M 484-026	Bolt, Hex, 5/16"-18, 1-1/2"
N 489-012	Washer, Flat, 1/4"
O 009-070	Base
P 009-012	Belt Guard
Q 209-001	Rubber Foot

Part No.	Description
020-094	Complete Rubber Barrel Assembly, 12 lb Capacity
R 020-102	Inner Lid w/Bolt
S 020-003	Outer Lid
T 481-070	Knurled Nut
U 240-012	Boot Gasket
V 240-005	Rubber Barrel Only
W 108-001	Barrel Washer

C100

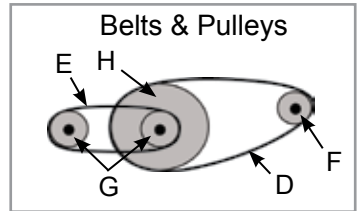
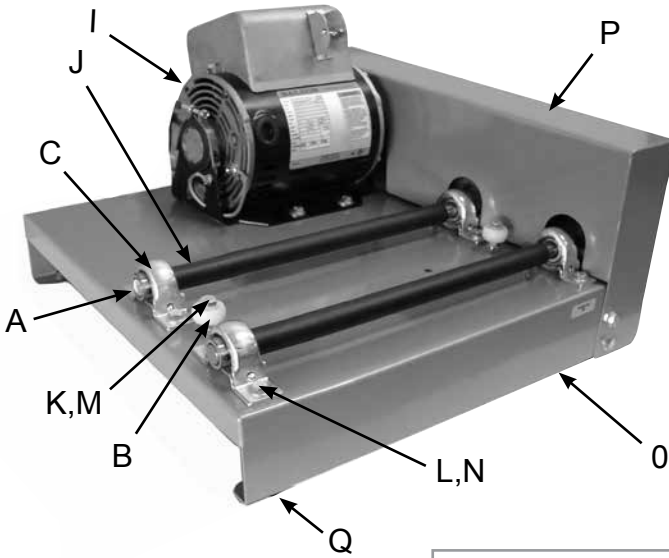

12 Lb. Barrel

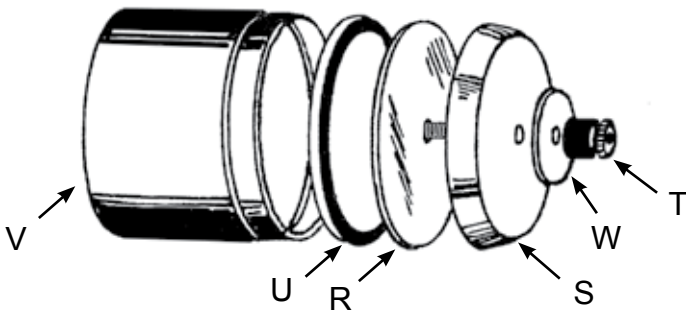

PARTS LIST C200

Part No.	Description
A 200-002	Bearing
B 203-920	Bearing, Nylon
C 204-002	Bearing Strap
D 210-023	Belt, Drive
E 210-025	Belt, Idler
F 211-001	Pulley, 1-1/2" x 1/2"
G 211-006	Pulley, 2" x 5/8"
H 211-041	Pulley, 5" x 5/8"
I 300-030	1/6 HP Motor
J 009-006	Shaft with cover
K 481-029	Nut, Hex, 5/16"-18 x 1-1/2"
L 484-015	Bolt, Hex, 1/4"-20, 3/4"
M 484-026	Bolt, Hex, 5/16"-18, 1-1/2"
N 489-012	Washer, Flat, 1/4"
O 009-071	Base
P 009-012	Belt Guard
Q 209-001	Rubber Foot

Part No.	Description
020-094	Complete Rubber Barrel Assembly, 12 lb Capacity
R 020-102	Inner Lid w/Bolt
S 020-003	Outer Lid
T 481-070	Knurled Nut
U 240-012	Boot Gasket
V 240-005	Rubber Barrel Only
W 108-001	Barrel Washer

C200

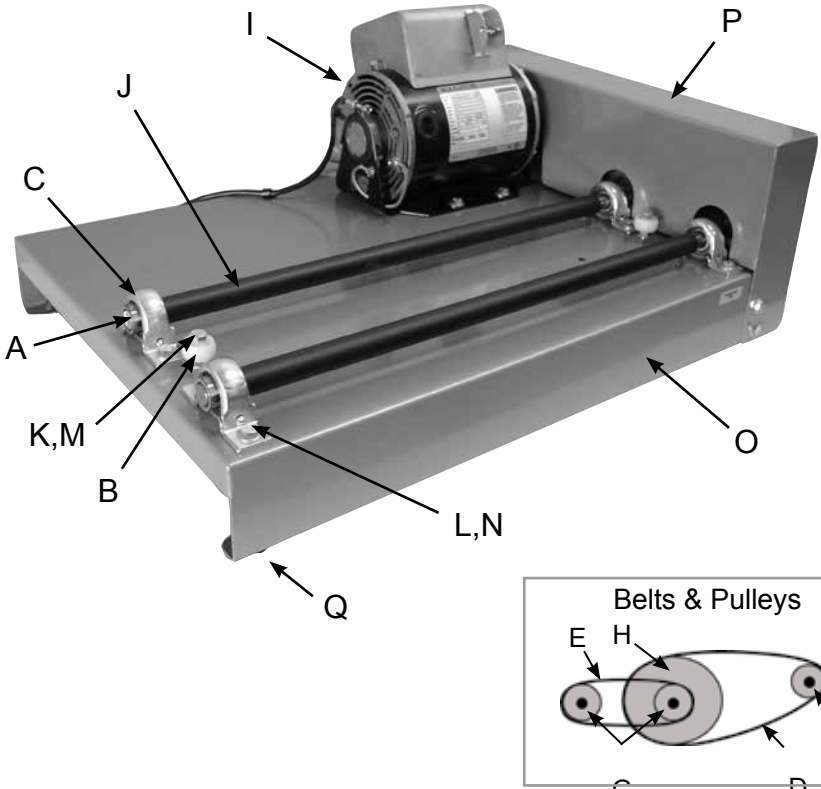

12 Lb. Barrel

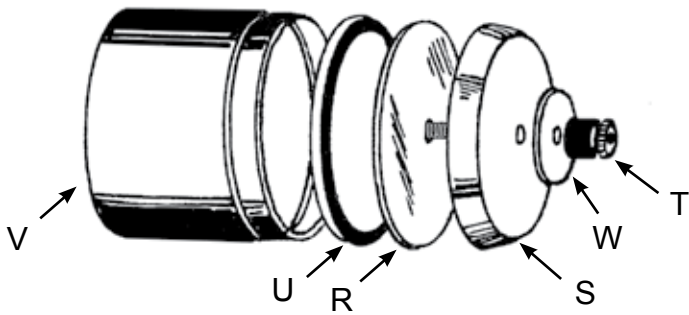

PARTS LIST C300

Part No.	Description
A 200-002	Bearing
B 203-920	Bearing, Nylon
C 204-002	Bearing Strap
D 210-023	Belt, Drive
E 210-025	Belt, Idler
F 211-001	Pulley, 1-1/2" x 1/2"
G 211-006	Pulley, 2" x 5/8"
H 211-041	Pulley, 5" x 5/8"
I 300-030	1/6 HP Motor
J 009-007	Shaft with cover
K 481-029	Nut, Hex, 5/16"-18 x 1-1/2"
L 484-015	Bolt, Hex, 1/4"-20, 3/4"
M 484-026	Bolt, Hex, 5/16"-18, 1-1/2"
N 489-012	Washer, Flat, 1/4"
O 009-072	Base
P 009-012	Belt Guard
Q 209-001	Rubber Foot

Part No.	Description
020-094	Complete Rubber Barrel Assembly, 12 lb Capacity
R 020-102	Inner Lid w/Bolt
S 020-003	Outer Lid
T 481-070	Knurled Nut
U 240-012	Boot Gasket
V 240-005	Rubber Barrel Only
W 108-001	Barrel Washer

C300

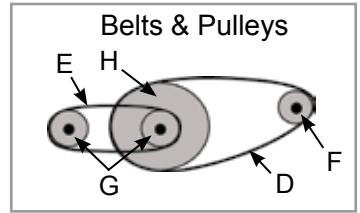
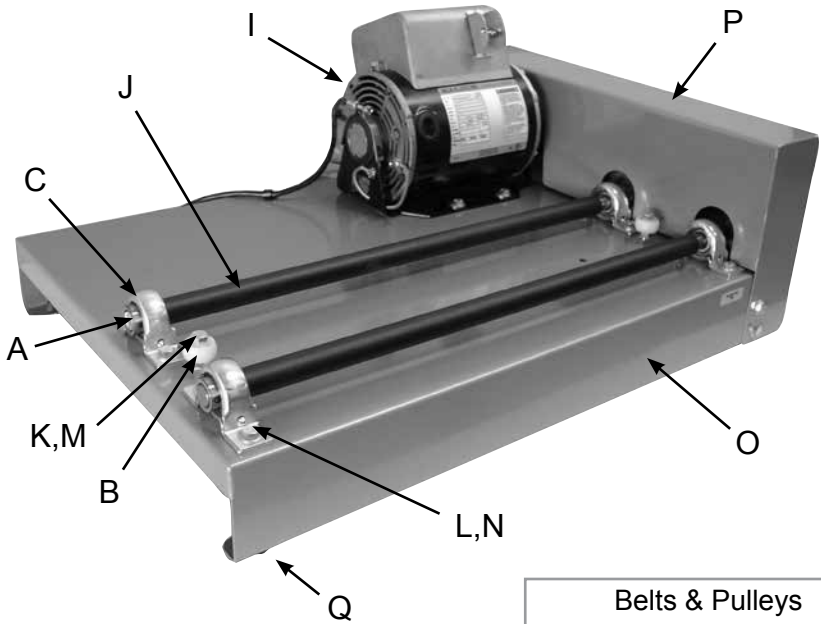

12 Lb. Barrel

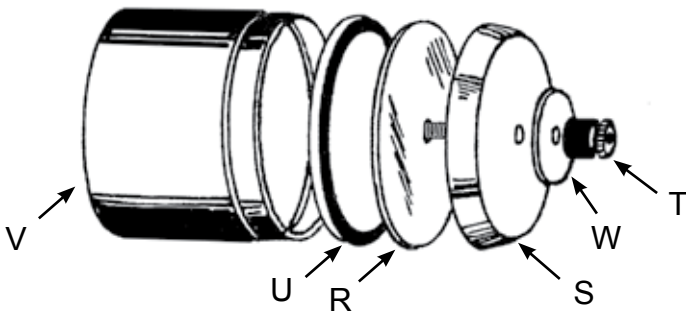

LORTONE Rotary Tumblers
are quiet, durable grinding
and polishing machines.
Follow these basic operating
and care instructions to help
keep your tumbler in optimal
running condition.

LORTONE

12130 Cyrus Way
Mukilteo, WA 98275
(425) 493-1600